

## DATA SHEET neon convertor Type MAXI 12035 K-19

- Available only in Standard versions.
- Compliant with standard EN 61347-2-10 for the **L.V. Directive**
- Compliant with standard EN 55015 3<sup>rd</sup> ed., EN 61547 for the **EMC Directive**
- **Type B** converter in accordance with EN 61347-2-10 (protection against secondary ground fault leakage is required)
- 230v. input, with 0,5m cable.
- Output with 0,6 m cable type **B** (Standard EN 50143). Insulation in silicon. External diameter 6,3mm. Section 1mm<sup>2</sup>

### Electrical data:

Input :	Voltage	Volt 230
	Current	Ampere 1,3 maximum
	Frequency	Hertz 50/60
	Power	Watt 165 maximum
	Power factor	$\lambda > 0.55$
	Output:	Voltage
	Nominal load current	mA 30
	Short circuit current	mA 35
	Frequency	Hertz 19.000

### Performances:

- In compliance with *Flashers (0.5sec. delay at switching on)*
- Not compliant with *Dimmers*
- Suitable both for lamps loaded with argon + mercury gas as well as with 100% neon gas (lack of "bubble" effect and of mercury migration)
- Supplied with ***open circuit protection, ground fault protection and protection against overloading***
- Maximum ambient temperature 40 c°
- Minimum ambient temperature -40c°
- Place 10mm far from metal surfaces

### Indicative chart of maximum loading for electronic converters

For every electrode couple 50cm must be calculated.

	d.8mm	d.10mm	d.12mm	d.15mm	d.18mm	d.20mm
Argon	mt 11	mt. 12,5	mt. 14,4	mt. 15,6	mt. 16,8	mt. 18
Neon	mt. 8	mt. 9	mt. 10,3	mt. 11,2	mt. 12	mt. 13,2

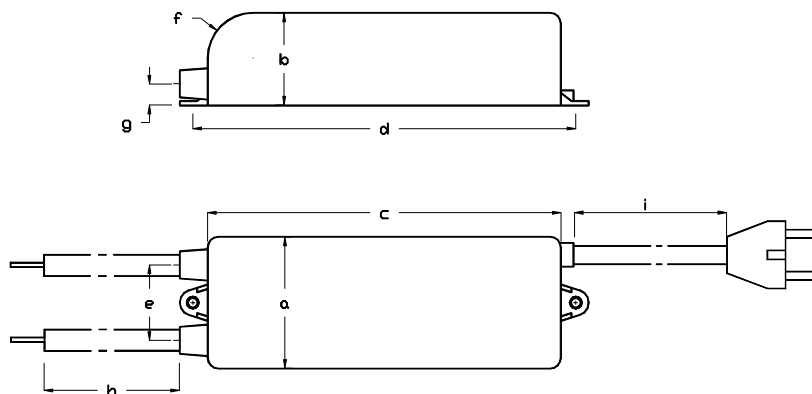

	a	b	c	d	e	f	g	h	i	weight
MAXI	59	46	163	178	35	21	10	600	500	1.100 g

All dimensions are in mm.

### INSTALLATION GUIDELINE

- To verify that the converter is not overloaded add to the lamps to be lit a 10 K $\Omega$  (11 watt) resistor. If tripping occurs, reduce the number of lamps to feed. To check for presence of installation problems, this test shall be performed when sign is finished.
- **For high voltage connections use the cable connected to the transformer with no further additions.**
- Keep the high voltage cables far from one another
- The lamps shall always be installed upon isolating supports: never lay the full length of the lamps upon any surface (including wood or chalk)
- Long life and reliability of the converter is assured by connecting in each installation one or more **SurgeDefenders** in the vicinity of the electric panel
- The converter must be, on all its' sides, **1 cm apart** from the metal surface.
- The converters must be at least **2 cm far** from one another.
- The distance between the lamps and parts with different potential (other lamps, current conductors, parts connected to earth) shall be suitable to the voltages on site which, at the frequencies produced by the converter, can discharge easily through air and unsuitable insulating material.
- The material of the supports of the lamps must be always insulating (EN 50107)

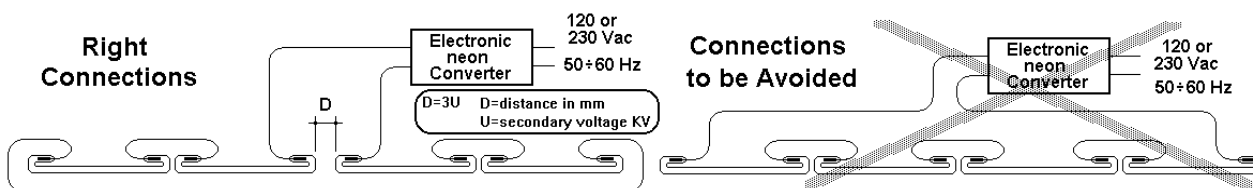

### Ozonelux : Warranty conditions

Warranty by Ozonelux srl is limited to faults arising from the components and from the manufacturing process.

Faults caused by external sources such as surge condition, improper use of the device and similar not complying with what depicted within the instruction for use provided by Ozonelux SRL, are not covered by warranty.

Ozonelux srl provides a two year warranty: this two year guarantee period is from the manufacturing date mentioned on the converter.

The faulty unit shall be returned to Ozonelux carriage paid.

The liability of Ozonelux srl is limited to the sale price of the unit which is found faulty after the control by Ozonelux srl.

Design **Electronica per luce**

**TECNOLUX**  
GROUP